

## KAPILUX TIM Transparent Insulation

Components for transparent insulation (TIM) should combine good thermal insulation with a high level of solar transmission.

In conjunction with a solid absorbent wall, KAPILUX TWD offers:

- considerable solar transmission for maximum energy output
- very good heat insulation
- saving the solar heat to heat the room
- saving heating energy

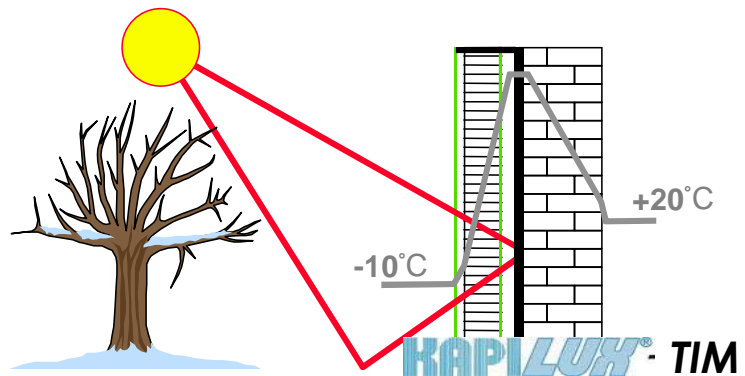

The sunlight is directed through the transparent insulation onto a dark absorber wall. The wall heats up and functions as a **solar heating system with time lag** for the rooms behind it.

KAPILUX TIM with its capillary structure is optimised for this process. The low U-value minimises thermal transmission losses through the façade. The high radiation and light transmission levels make solar energy useful for heating rooms, and also for lighting with natural light in daylight systems.

Correctly installed systems produce energy gains of 100 - 150 kWh/m<sup>2</sup>a, corresponding to 10 - 15 l fuel oil per square metre of transparent insulation per year.

### Technical data

U-value	0.7	W/(m <sup>2</sup> K)
U-value	0,12	Btu/hr/ft <sup>2</sup> /°F
TSET	58	%
T <sub>v</sub>	70	%
R <sub>w</sub>	43	%

Legend and related values:

	unit	standard	technical term
<b>U</b>	W/(m <sup>2</sup> K)	DIN EN 673 DIN EN 674	Thermal transmittance, $U_g = U$
<b>TSET</b>	%	DIN EN 410	Total solar energy transmittance or solar heat gain coefficient
<b>T<sub>v</sub></b>	%	DIN EN 410	Light transmission (direct/hemispheric)
<b>R<sub>w</sub></b>	dB	DIN EN 20140	Sound reduction coefficient

The above data are approximate data. They are based on measurements of recognized test institutes and calculations derived from these measurements.

At the moment, not all suppliers have adapted their key data to the currently applicable regulations. When making comparisons, please pay attention to the relevant manufacturer's notes. On the basis of the old standards, total solar energy transmittances as well as shading coefficient values are each 1-3% lower, the former U-value according to DIBt/DIN is 0.1 W/(m<sup>2</sup>K) lower.

U-values refer to European Standard EN 673. Please contact our sales department for values according to ASHRAE conditions.

TSET (total solar energy transmittance or solar heat gain coefficient) and transmission values refer to European Standard EN 410. Values according to ISO 9050 may differ by 1-2%.

## Structure

KAPILUX TWD is a glass panel, consisting of a toughened inner and outer pane for weather protection and KAPIPANE, made of PMMA (acrylic), in the cavity. The perimeter is hermetically sealed, and the element is filled with inert gas. The significant advantages of this element compared to panels with pressure compensation openings and tubes are the thickness of the element, which is reduced by approx. 50 % for the same U-value, and the simplified handling.

The actual thickness and type of glass must be determined to take account of static requirements. Please quote the installation altitude above sea level in all correspondence. The standard structure for façade applications can be seen in the sketch.

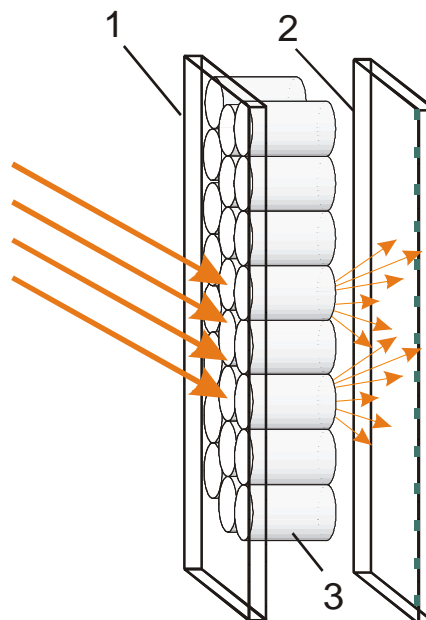

- 1: External toughened glass 5 mm
- 2: Internal toughened glass 4 mm, coated
- 3: KAPIPANE capillary slab

## Dimensions and installation

The dimension of the hermetically sealed KAPILUX panels is limited to a minimum of 1000 x 1000 mm and a maximum of 2000 x 2000 mm. For widths of more than 1300 mm and heights of more than 1300 mm the capillary slab has to be divided by T-profiles. In this case, the capillary slab is assembled from two or more KAPIPANE pieces. Profiles with a view width of 25 mm (from the inside) guarantee the dimensional stability of the capillary slabs.

On account of the hermetic seal, the glass panes may either bulge or dent (on the outer pane up to approx.  $\pm 5$  mm, on the inner pane up to approx.  $\pm 10$  mm). The maximum temperature stability of the capillary slab is 80°C, the panels should not be used at consistent temperature levels of 60°C or higher.

KAPILUX TIM is a hermetically sealed insulating glass with installation thicknesses of up to 49 mm. This build-up protects the transparent insulation material permanently against dirt accumulation and moisture. KAPILUX TIM also hardly differs from conventional insulating glass in installation. Some recommendations for the use of an absorber wall are given in the following.

- (1) To guarantee a high level of efficiency of the transparent insulation, thermal bridges in the façade construction must be avoided as far as possible. This is particularly important as high surface temperatures reinforce the influence of thermal bridges.
- (2) Thanks to the buffer effect of a heavy wall, solar energy can be optimally used for room heating purposes. For good thermal storage and conduction, heavy wall construction materials must be used, e.g. chalky sandstone, rubble stone, natural stone or concrete. We recommend a density of at least 1.400 kg/m<sup>3</sup>.
- (3) The air gap between the panel and the absorber wall must be at least 2 cm in order to allow for the movement of the inner pane and at the same time to maintain a thermally insulating air cushion. To avoid losses, it should be sealed element for element and should be drained and ventilated from below.
- (4) As absorber coating black paint with as high an absorption rate as possible should be used (e.g. StoSolar-Absorber-Spachtel, Sto AG or M 40 Li solar paint, Transfer-Electric GmbH, 49442 Lemförde, Tel. 05443-1808). Lighter colours are possible, but these reduce the energy gain.

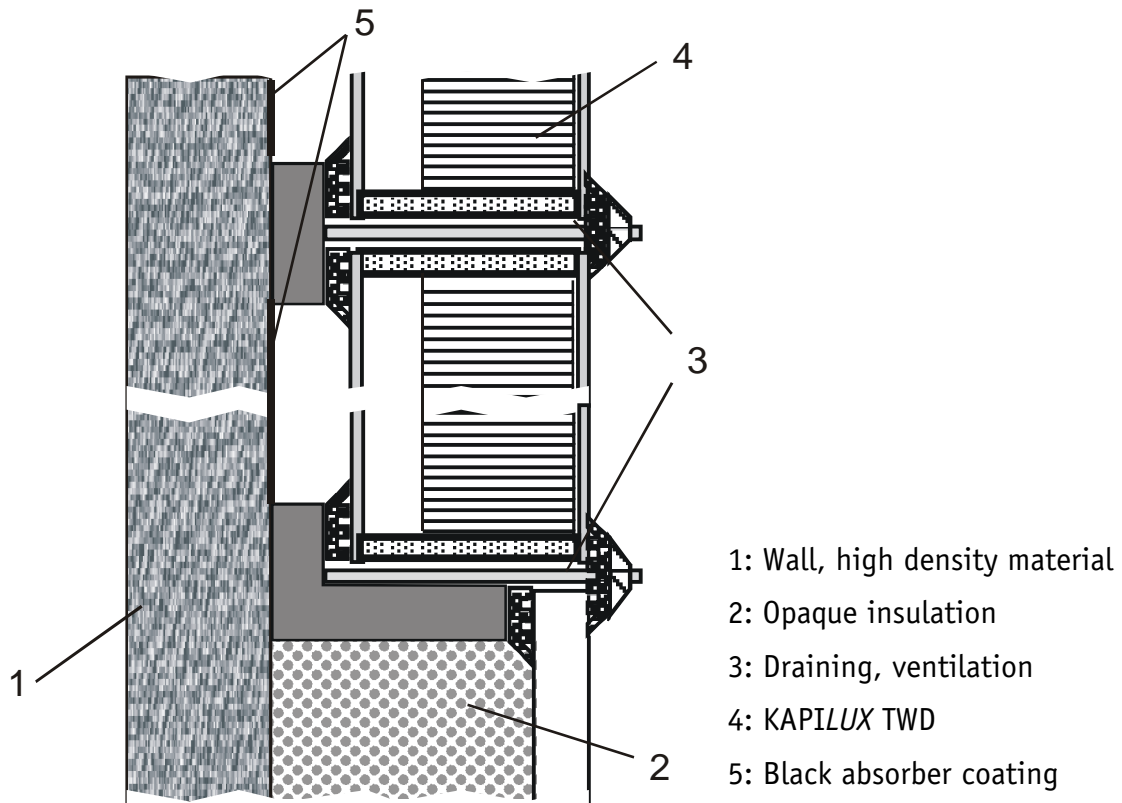

- (5) The transparently insulated wall should not be obstructed by large pieces of furniture, in order to allow the heat to be radiated into the room.
- (6) Between the TIM and the wall, there must not be any components that absorb solar radiation and at the same time do not have a good thermal link to the wall. Such components can heat up very much and can lead to damage in the TIM module. This risk also exists if the recommendation concerning high bulk density for the wall material is not followed or if very thin walls are built.
- (7) To prevent overheating in the summer, solar protection is required. Electrically driven window blinds or roller shutters are the preferred solution. Seasonal sunshades are also possible (e.g. manually mounted cover plates). Roof projections may also be used as solar protection, but these reduce the energy received all the year round.
- (8) The simplest regulation for electrically driven shade systems is an astronomical clock, which opens the curtain material in winter mode when the sun rises and closes it when the sun sets. It must be possible to invert this operation by means of a manual switch (summer mode).

Since the above-mentioned recommendations cannot take account of every individual case, they are neither complete nor do they represent compulsory instructions. All current laws, regulations, standards and recognised rules of technology at the place of installation must be observed.

## Planning instructions

Solar walls are intended to save heating energy and increase the thermal comfort in the room. For successful installation, the planner must take account of a number of TIM-specific aspects.

## Energy gains

The heating cost savings that can actually be achieved per square metre of transparent insulation and per year depend on a large number of influencing variables.

The critical variables include:

- total solar energy transmittance (preferably high total solar energy transmittance for the entire system, no shade caused by surrounding buildings or vegetation)
- U-value of the transparent insulation material (preferably low U-value)
- Orientation (preferably southern orientation  $\pm 30^\circ$ )
- Bulk density of outer wall (preferably high bulk density between 1400 .. 2000 kg/m<sup>3</sup> for a good buffer effect with time lag)

Other influencing variables are:

- location (better sunny-cold climate), heating period (better long)
- surface proportion of transparent insulation material, with respect to façade surface area (relatively uncritical, e.g. between 25 and 40%)
- thickness of the outer wall (relatively uncritical, e.g. between 20 and 30 cm)
- internal heat sources (savings fall with the performance of the internal heat sources)

## Thermal comfort

Well-being in a room is determined, amongst other things, by the perceived temperature. The perceived temperature is calculated from equal parts of air temperature and the radiation temperature of the surfaces forming the room boundaries.

In winter, a seat beside a cool wall is generally felt to be unpleasant. On the other hand, the transparent insulation wall heated by the winter sun reaches temperatures of over 25° on the inside, and thus radiates pleasant warmth.

The heat is released with a time lag, and with sufficient thermal storage mass in the wall, it can retain warmth well into the evening.

In summer and sometimes also in the transitional period, the solar energy received through the unshaded transparent insulation can also lead to (equally delayed) overheating of the room behind the wall.

The following variables have an influence on this:

- orientation (critical, preferably southern orientation)
- dense outer wall (critical, preferably high bulk density values)
- shade (on the southern façade, projections have a protecting influence)
- length of the heating period (preferably long)
- ventilation option with time lag

If the contribution of the transparent insulation to the overheating of the room is to be completely disabled, there is practically no alternative to an adjustable solar protection system. Such a system switches the total solar energy transmittance of the transparent insulation to lowest possible values, as required.

## **Visual appearance of KAPILUX TIM**

Slight fluctuations in the density of the capillary slab and the diameter of the capillaries, as well as production-specific joints, will be detectable. These "variations" in appearance give the product a lively appearance. Under certain lighting conditions, fine lines may also become apparent within the capillary slab.